



Flange ball valve KFK-C, steel, short face-to-face length With DIN flange

DN 15 - 250 mm PN max. 40 bar

Series 25 – PN 10 according to DIN EN 1092-1
26 – PN 16 according to DIN EN 1092-1
27 – PN 25 according to DIN EN 1092-1
28 – PN 40 according to DIN EN 1092-1

Face-to-face lengths DIN EN 558 FTF basic series 27 (formerly: DIN 3202-1 Series F4)

Temperature range Standard: -10°C to +150°C; DVGW -20°C to +60°C
On request: -50°C to +250°C

Range of use Liquids: Liquids group 1 and 2 according to PED 2014/68/EU Article 13
Gases: Liquids group 1 and 2 according to PED 2014/68/EU Article 13
As a matter of principle, the resistance to the flow medium must be ensured.

Approvals Series 26, 28: DVGW for gas
TÜV-Component mark
Technical instructions on air quality control (TA Luft)

Technical specification The KFK-C type ball valve consists of a 3-part body, from DN 50 of a 2-part body. Up to nominal width DN 50, the flange is screwed into the body. From nominal width DN 65, the two body parts are flanged together. The stem is blowout-proof and, from nominal width DN 32 is provided with a two-fold O-ring seal.

Technical data KFK-C

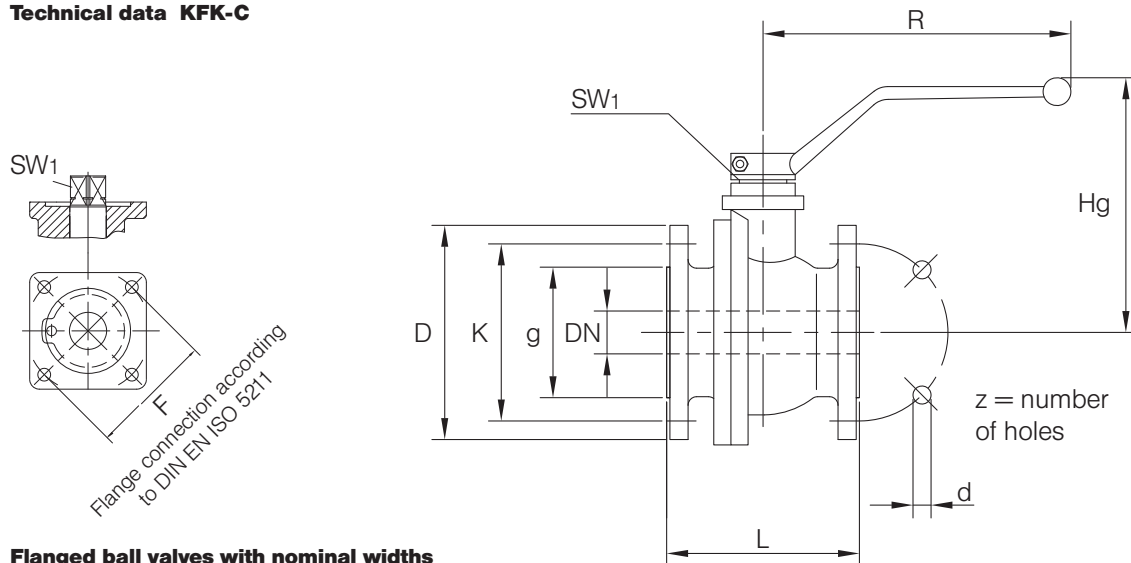

Flanged ball valves with nominal widths DN 15 to DN 50 of series 28 (PN 40) are supplied, as agreed, with swivelling flanges.

Series 25 (PN 10 according to DIN EN 1092-1)

DN mm	PN bar	L mm	D mm	g mm	K mm	z	d mm	Hg mm	R mm	F DIN EN ISO 5211	SW1 mm	Weight kg
15	40	115	95	45	65	4	14	69	130		10	2.4
20	40	120	105	58	75	4	14	71	130		10	3.3
25	40	125	115	68	85	4	14	82	160		10	4.5
32	40	130	140	78	100	4	18	117	250		17	6.7
40	40	140	150	88	110	4	18	121	250		17	8.0
50	40	150	165	102	125	4	18	128	250	F07	17	10.0
65	16	170	185	122	145	4	18	158	250		17	19.0
80	40	180	200	138	160	8	18	182	370	F10	22	25.0
100	16	190	220	158	180	8	18	194	370	F10	22	30.0
125	16	325	250	188	210	8	18	195	520	F10	22	50.0
150	16	350	285	212	240	8	22	225	700	F12	27	72.0
200	10	400	340	268	295	8	22	260	700	F12	27	108.0
250*	10	450	395	320	350	12	22	260	700	F12	27	135.0

*Reduced bore, clear span 200.

Series 26 (PN 16 according to DIN EN 1092-1)

DN mm	PN bar	L mm	D mm	g mm	K mm	z	d mm	Hg mm	R mm	F DIN EN ISO 5211	SW1 mm	Weight kg
15	40	115	95	45	65	4	14	69	130		10	2.4
20	40	120	105	58	75	4	14	71	130		10	3.3
25	40	125	115	68	85	4	14	82	160		10	4.5
32	40	130	140	78	100	4	18	117	250		17	6.7
40	40	140	150	88	110	4	18	121	250		17	8.0
50	40	150	165	102	125	4	18	128	250	F07	17	10.0
65	16	170	185	122	145	4	18	158	250		17	19.0
80	40	180	200	138	160	8	18	182	370	F10	22	25.0
100	16	190	220	158	180	8	18	194	370	F10	22	30.0
125	16	325	250	188	210	8	18	195	520	F10	22	50.0
150	16	350	285	212	240	8	22	225	700	F12	27	72.0
200	16	400	340	268	295	12	22	260	700	F12	27	108.0
250*	16	450	405	320	355	12	22	260	700	F12	27	135.0

*Reduced bore, clear span 200.

Series 27 (PN 25 according to DIN EN 1092-1)

DN mm	PN bar	L mm	D mm	g mm	K mm	z	d mm	Hg mm	R mm	F DIN EN ISO 5211	SW1 mm	Weight kg
15	40	115	95	45	65	4	14	69	130		10	2.4
20	40	120	105	58	75	4	14	71	130		10	3.3
25	40	125	115	68	85	4	14	82	160		10	4.5
32	40	130	140	78	100	4	18	117	250		17	6.7
40	40	140	150	88	110	4	18	121	250		17	8.0
50	40	150	165	102	125	4	18	128	250	F07	17	10.0
65	40	170	185	122	145	8	18	158	250		17	19.0
80	40	180	200	138	160	8	18	182	370	F10	22	25.0
100	40	190	235	162	190	8	22	194	370	F10	22	30.0
125	40	325	270	188	220	8	26	195	520	F10	22	50.0
150	40	350	300	218	250	8	26	225	700	F12	27	72.0
200	25	400	360	278	310	12	26	260	700	F12	27	108.0
250*	25	450	425	335	370	12	30	260	700	F12	27	135.0

*Reduced bore, clear span 200.

Series 28 (PN 40 according to DIN EN 1092-1)

DN mm	PN bar	L mm	D mm	g mm	K mm	z	d mm	Hg mm	R mm	F DIN EN ISO 5211	SW1 mm	Weight kg
15	40	115	95	45	65	4	14	69	130		10	2.4
20	40	120	105	58	75	4	14	71	130		10	3.3
25	40	125	115	68	85	4	14	82	160		10	4.5
32	40	130	140	78	100	4	18	117	250		17	6.7
40	40	140	150	88	110	4	18	121	250		17	8.0
50	40	150	165	102	125	4	18	128	250	F07	17	10.0
65	40	170	185	122	145	8	18	158	250		17	19.0
80	40	180	200	138	160	8	18	182	370	F10	22	25.0
100	40	190	235	162	190	8	22	194	370	F10	22	30.0
125	40	325	270	188	220	8	26	195	520	F10	22	50.0
150	40	350	300	218	250	8	26	225	700	F12	27	72.0
200	40	400	375	285	320	12	30	260	700	F12	27	108.0
250*	40	450	450	345	385	12	38	260	700	F12	27	135.0

*Reduced bore, clear span 200.

Example of order: Ball valve type KFK-C DN 100 with flanged connection PN 16 according to DIN EN 1092-1
KFK-C 100 26

Parts list KFK-C

Pos.	Designation	Material
10	Body	Forged steel, steel casting
20	Flange	Steel, steel casting
30	Ball	Brass, steel, grey cast iron
40	Seal	PTFE
50	Stop washer	Steel
60	Stem	Brass, steel
70	Fitting	Brass
80	O-ring	NBR, FPM
90	Hand lever	Zinc die casting, casting
100	O-ring	NBR, FPM
110	Bolt	
120	Nut	
	Washer	
130	O-ring	NBR, FPM
	Sliding ring	PTFE
140	Stop pin	
160	Bolt	
180	Pin	Steel
190	Bearing shell	
200	O-ring	NBR, FPM

*Standard (can vary according to nominal width), other materials on request.
Due to the design, not all items are used for all nominal widths.

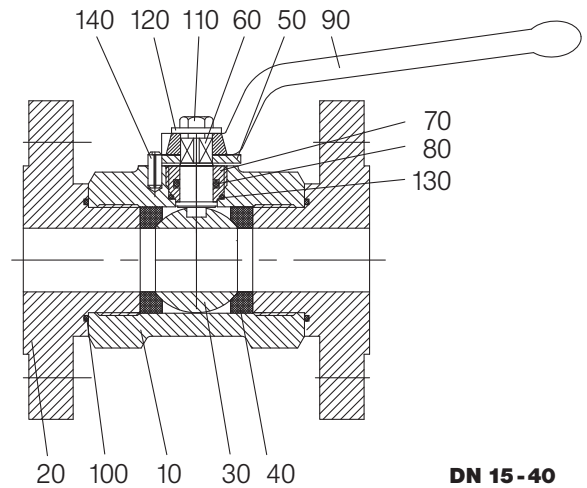

DN 15-40

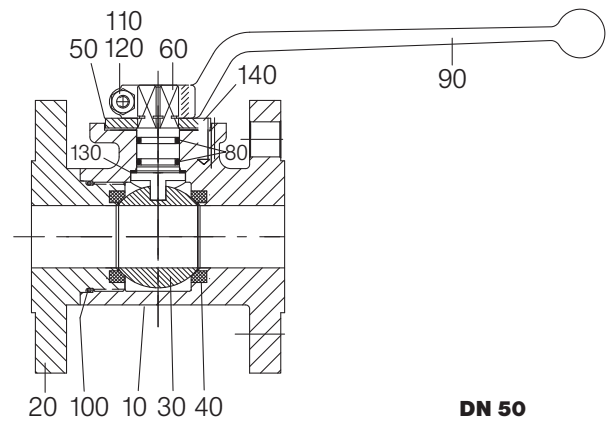

DN 50

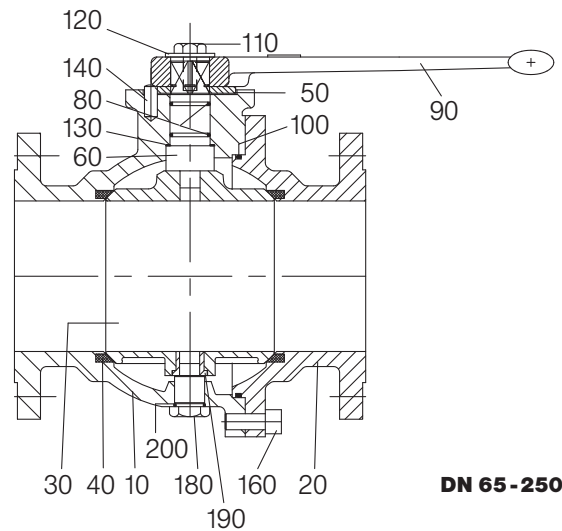

DN 65-250

2-way ball valves
with flange connection

Please ask separately, where requirements exceed the standard conditions of use listed in this data sheet.
As a matter of principle, the operating and maintenance instructions, in particular the safety instructions must be observed!
Operating and maintenance instructions as well as the approval certificates can be downloaded at www.von-scheven.de.

We reserve the right to carry out technical modifications.