



Ball valve NSK-AF-C and HSK-AF-C, steel With fixed weld ends

DN 8 - 50 mm PN max. 40 bar/PN max. 400 bar

Series 40 – with fixed weld ends: up to PN 40 – NSK-AF-C
up to PN 400 – HSK-AF-C

Temperature range Standard: -10°C to +150°C
On request: -50°C to +250°C

Range of use Liquids: Liquids group 1 and 2 according to PED 2014/68/EU Article 13
Gases: Liquids group 1 and 2 according to PED 2014/68/EU Article 13
As a matter of principle, the resistance to the flow medium must be ensured.

Technical specification The NSK-AF-C and HSK-AF-C ball valves are equipped with fixed weld ends on both sides. The stem seal is maintenance-free.

Please ask separately, where requirements exceed the standard conditions of use listed in this data sheet.

As a matter of principle, the operating and maintenance instructions, in particular the safety instructions must be observed!
Operating and maintenance instructions as well as the approval certificates can be downloaded at www.von-scheven.de.

We reserve the right to carry out technical modifications.

Technical data NSK-AF-C HSK-AF-C

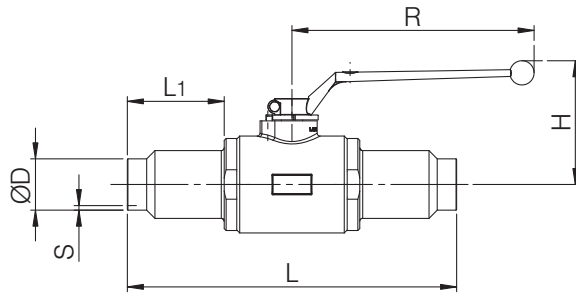

DN mm	NSK-AF-C PN bar	HSK-AF-C PN bar	L mm	L1 mm	D* mm	S* mm	H mm	R mm	Weight kg
8	40	400	262	100	13.5	2.3	77	112	0.7
10	40	400	262	100	17.2	2.3	77	112	0.8
15	40	400	279	100	21.3	2.6	67	130	1.1
20	40	400	284	100	26.9	3.2	71	130	1.6
25	40	400	298	100	33.7	3.2	82	160	2.3
32	40	400	309	100	42.4	3.2	117	250	4.5
40	40	400	276	80	48.3	3.2	121	250	4.2
50	40	400	294	80	60.3	3.6	128	250	8.5

*Other pipe dimensions are possible on request.

Example of order: NSK-AF-C type ball valve made of steel, DN 25 PN 40 with fixed weld ends
NSK-AF-C 25 40

Parts list		NSK-AF-C	HSK-AF-C
Pos.	Designation	Material*	Material*
10	Body	Steel	Steel
20	Fitting	Steel	Steel
30	Ball	Brass	Steel
40	Seal	PTFE	POM
50	Stop washer	Steel	Steel
60	Stem	Steel	Steel
80	O-ring	NBR/FPM	NBR/FPM
90	Hand lever	Zinc die-casting	Zinc die-casting
100	O-ring	NBR/FPM	NBR/FPM
110	Bolt		
120	Washer		
130	Sliding ring	PTFE	PTFE
	O-ring	NBR/FPM	NBR/FPM
140	Stop pin		

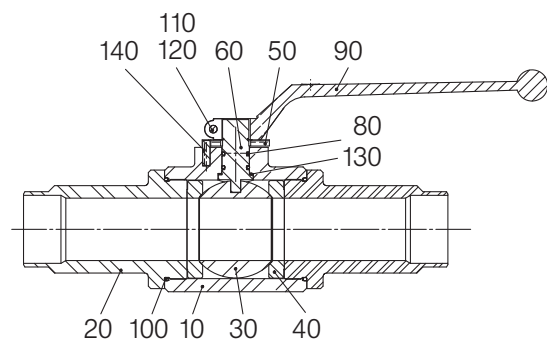

*Standard (can vary according to nominal width), other materials on request.
 Due to the design, not all items are used for all nominal widths.